

- i**
- MICRO
- TITAN
- TPH
- TPS
- TPF**

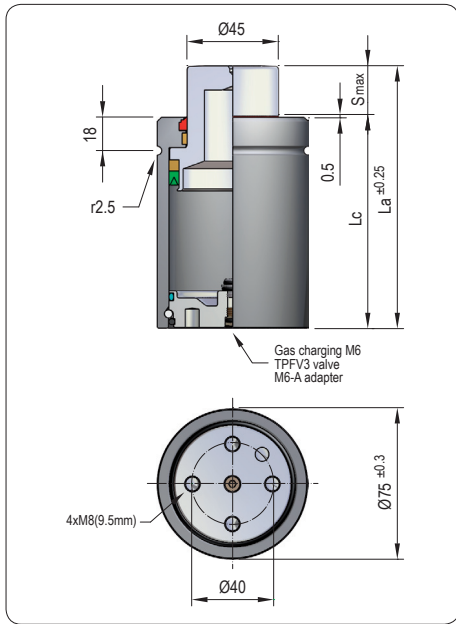

- i** Pressure medium Gas Nitrógeno (N₂)
- Max. charging pressure 150 Bar
- Min. charging pressure 50 Bar
- Piston seal area 31,17 cm²
- Operating temperature 0°C - 80°C
- Force increase by temperature 0,33 %/°C
- Max. stem speed 20 m/min
- Maintenance kit Kit F4000

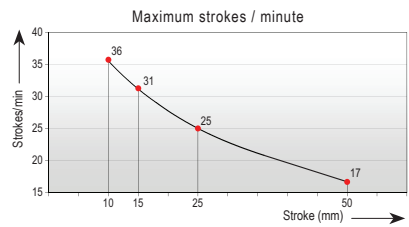

Code	Smax mm	La mm	Lc mm	Fa daN	90% F daN	100% Fc daN	P Bar	V l	Kg
TPF 4000x10	10	85	75	4000 (±5%)	5550	5800	128 (20°C)	0,100	1,55
TPF 4000x15	15	100	85		5865	6190		0,132	1,69
TPF 4000x25	25	130	105		6105	6485		0,203	2,02
TPF 4000x50	50	205	155		6385	6845		0,374	2,75

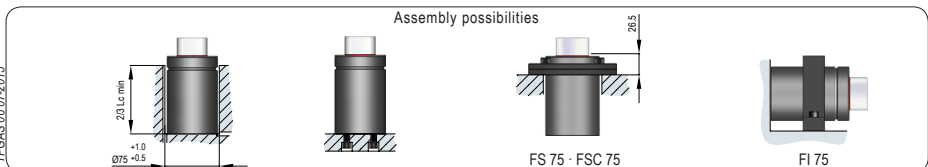
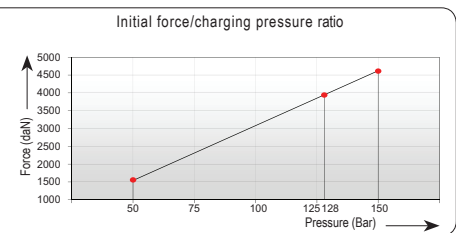
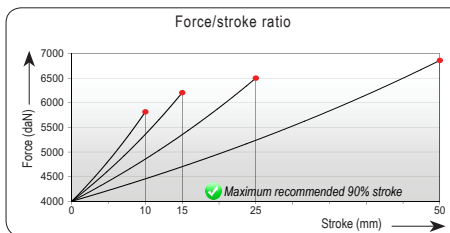

TRGAS 06/07-2015