



MICRO

TITAN

TPH

TPS

TPSP

TPF

TPK

TPC

TPCT

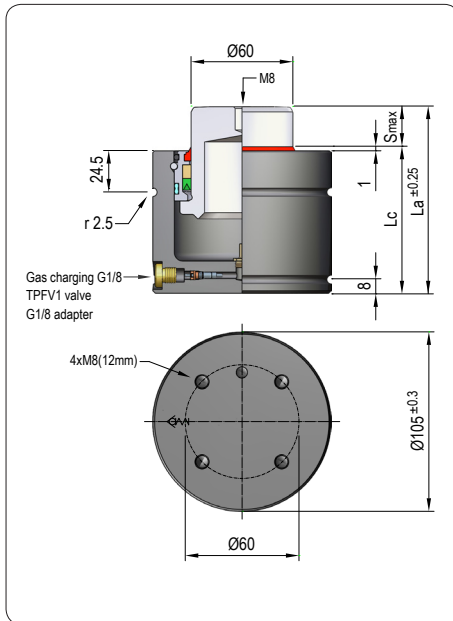

Pressure medium	Gas Nitrógeno (N ₂)
Max. charging pressure	175 Bar
Min. charging pressure	35 Bar
Rod seal area	28,27 cm ²
Operating temperature	0°C - 80°C
Force increase by temperature	0,33 %/°C
Max. stem speed	1,6 m/s
Maintenance kit	Kit CT5000

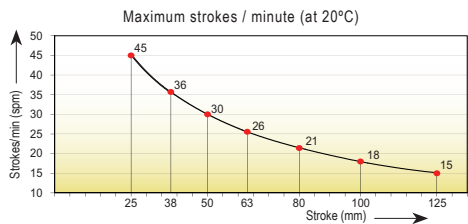

Code	Smax mm	La mm	Lc mm	Fa daN	90% F daN	100% Fc daN	P Bar	V l	Kg
TPCT 5000x25	25	110	85	5000 ±5% (20°C)	7395	7810	175 (20°C)	0,197	4,10
TPCT 5000x38	38	136	98		7615	8085		0,282	4,70
TPCT 5000x50	50	160	110		7735	8235		0,361	4,90
TPCT 5000x63	63	186	123		7815	8335		0,446	5,40
TPCT 5000x80	80	220	140		7890	8425		0,557	5,75
TPCT 5000x100	100	260	160		7945	8495		0,688	5,90
TPCT 5000x125	125	310	185		7990	8555		0,852	7,05

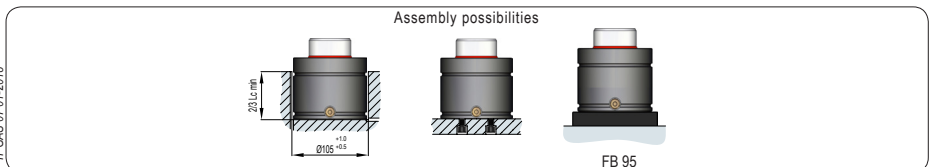
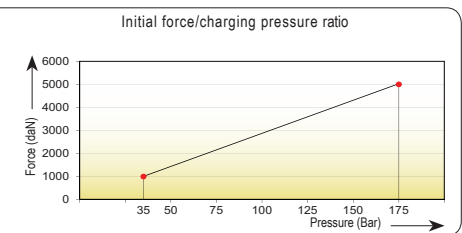
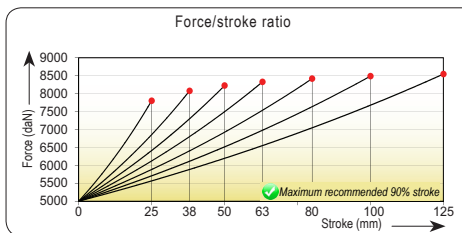

TPGAS 07/01-2018